

---

# **Designs for Bipolar Logic Families**

**Somchai Prasitjutrakul**

---

# TTL : NAND Gates

---

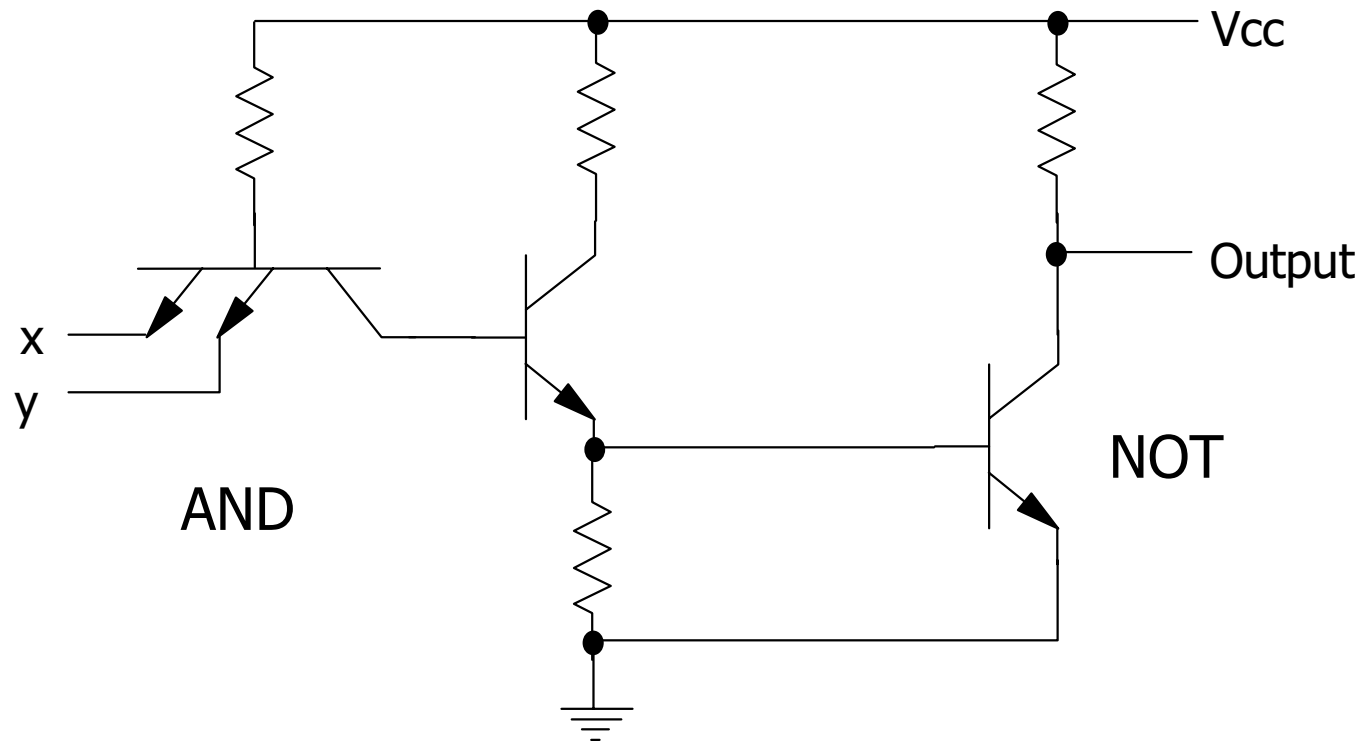

# TTL : NOR Gates

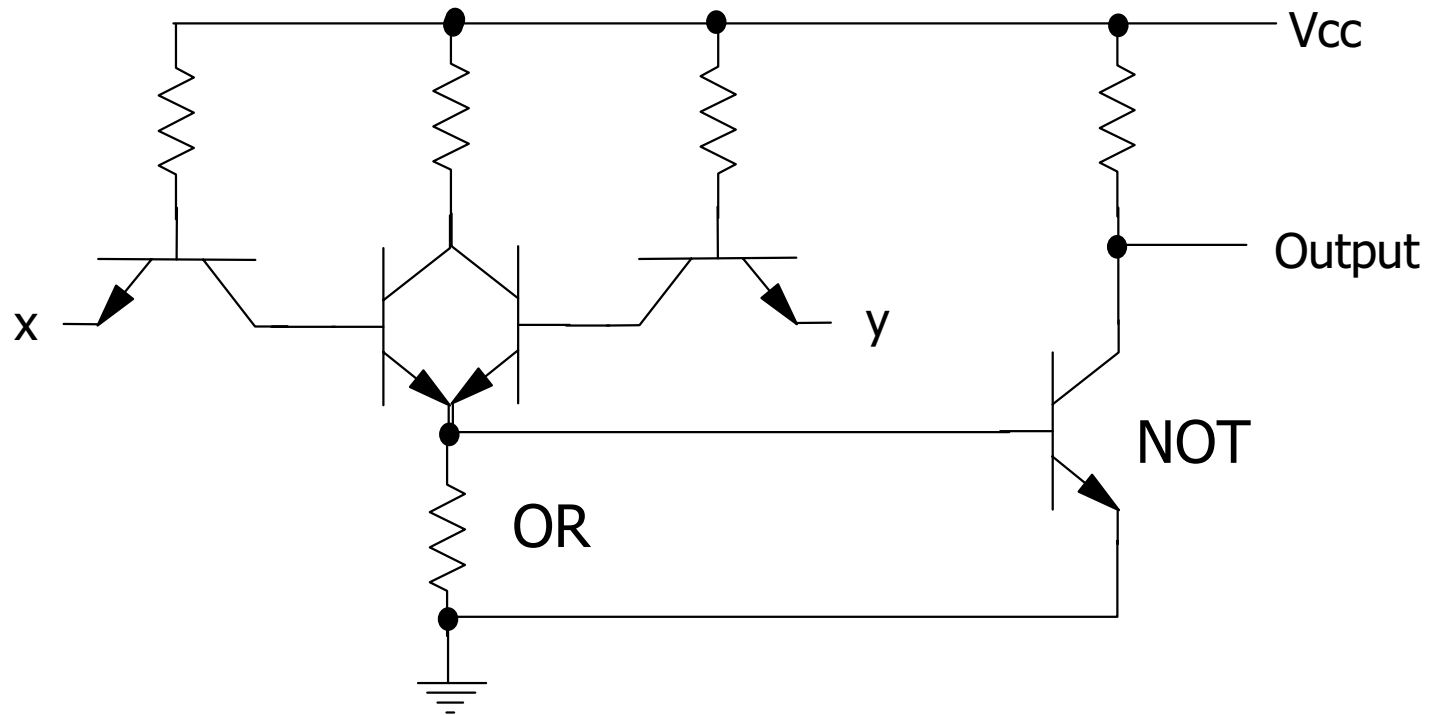

# TTL : AND-OR-INVERTER

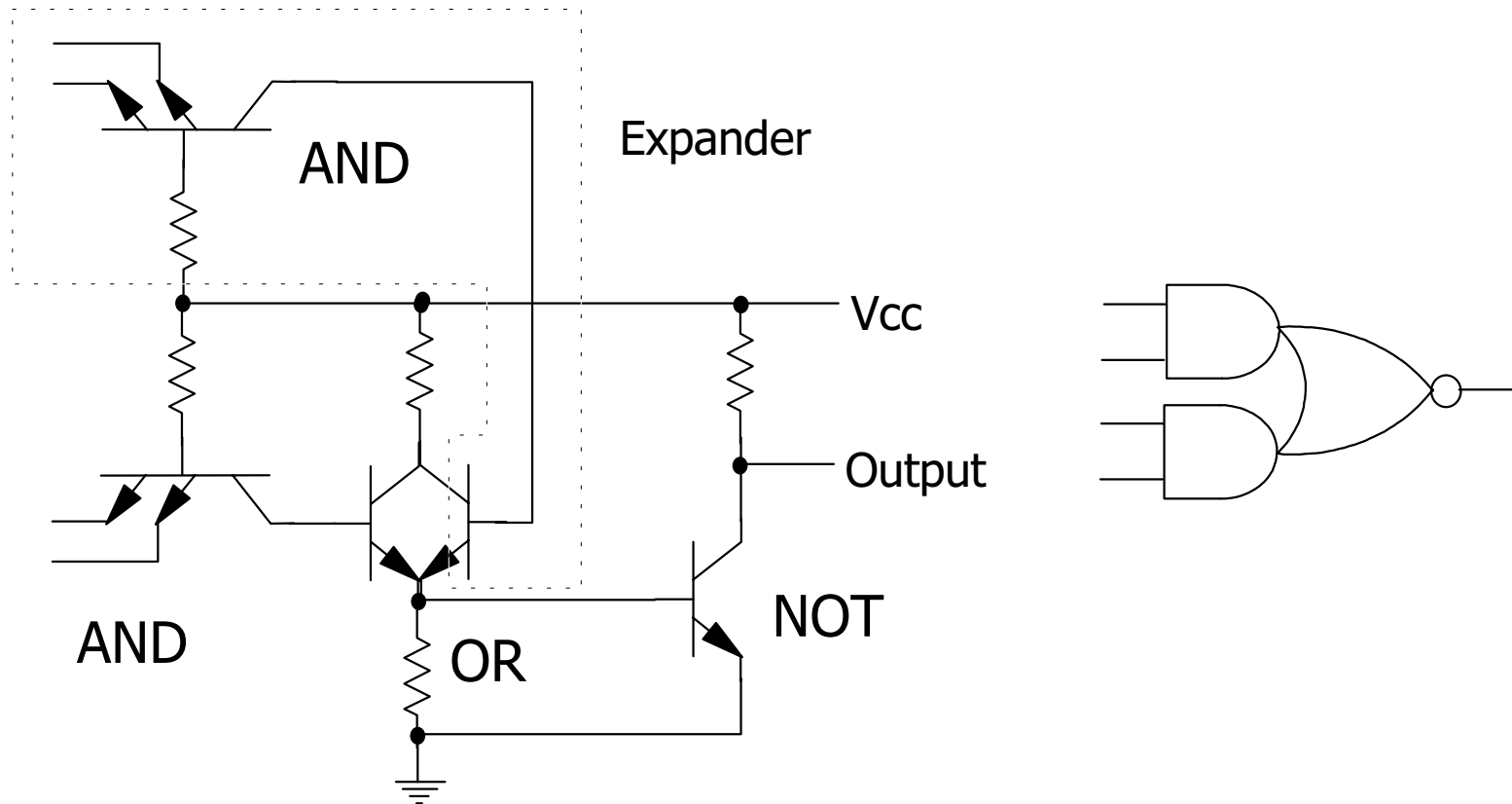

# TTL : AND Gates

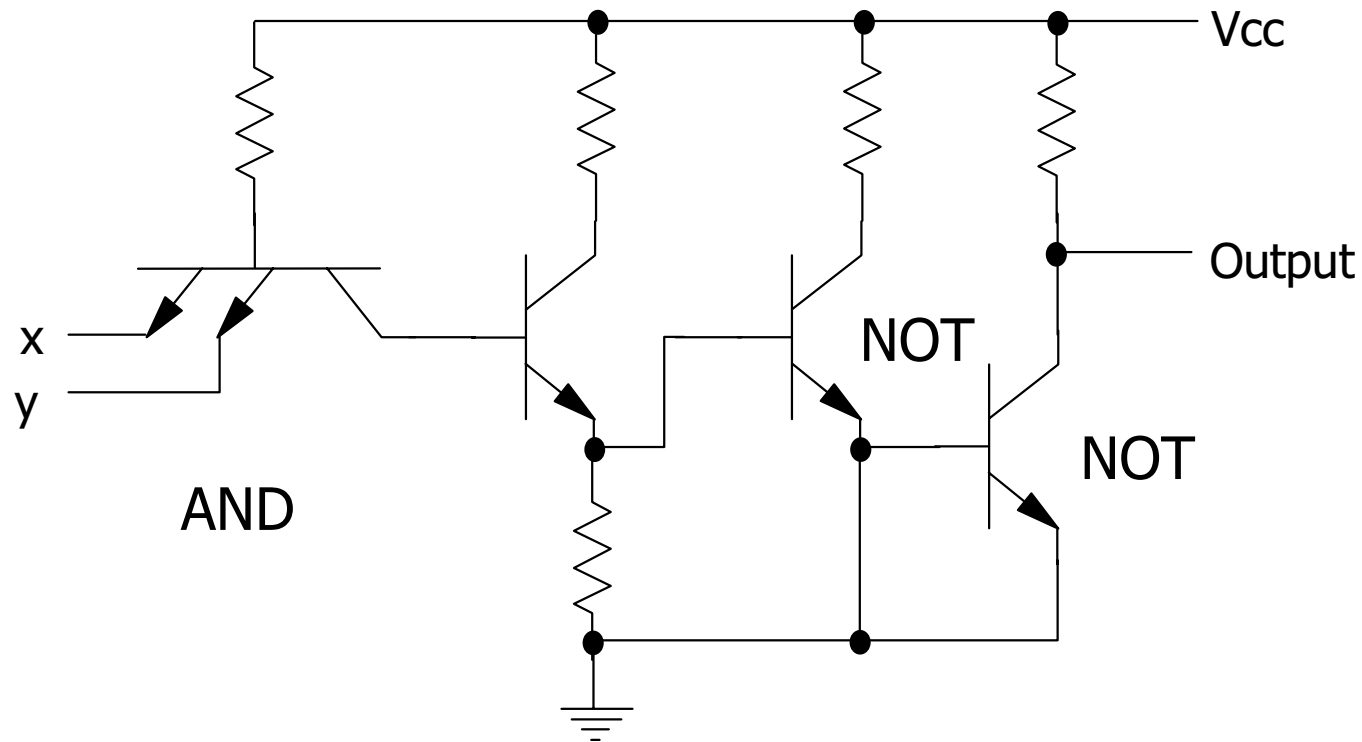

# Wired-AND of TTL Gates

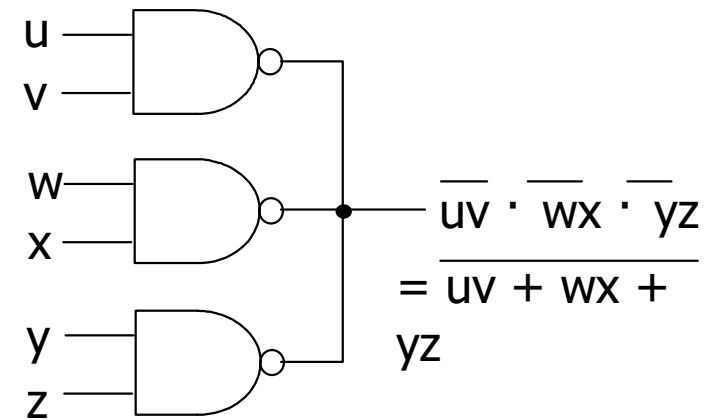
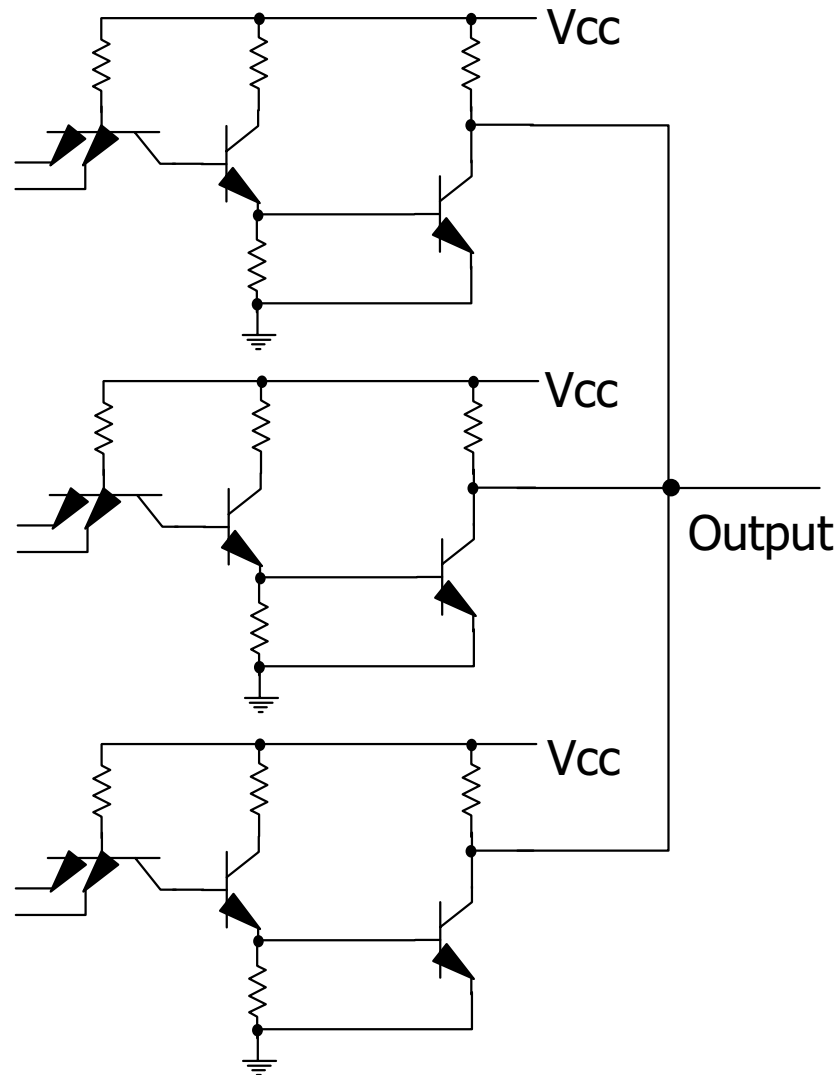

# Basic ECL Gates

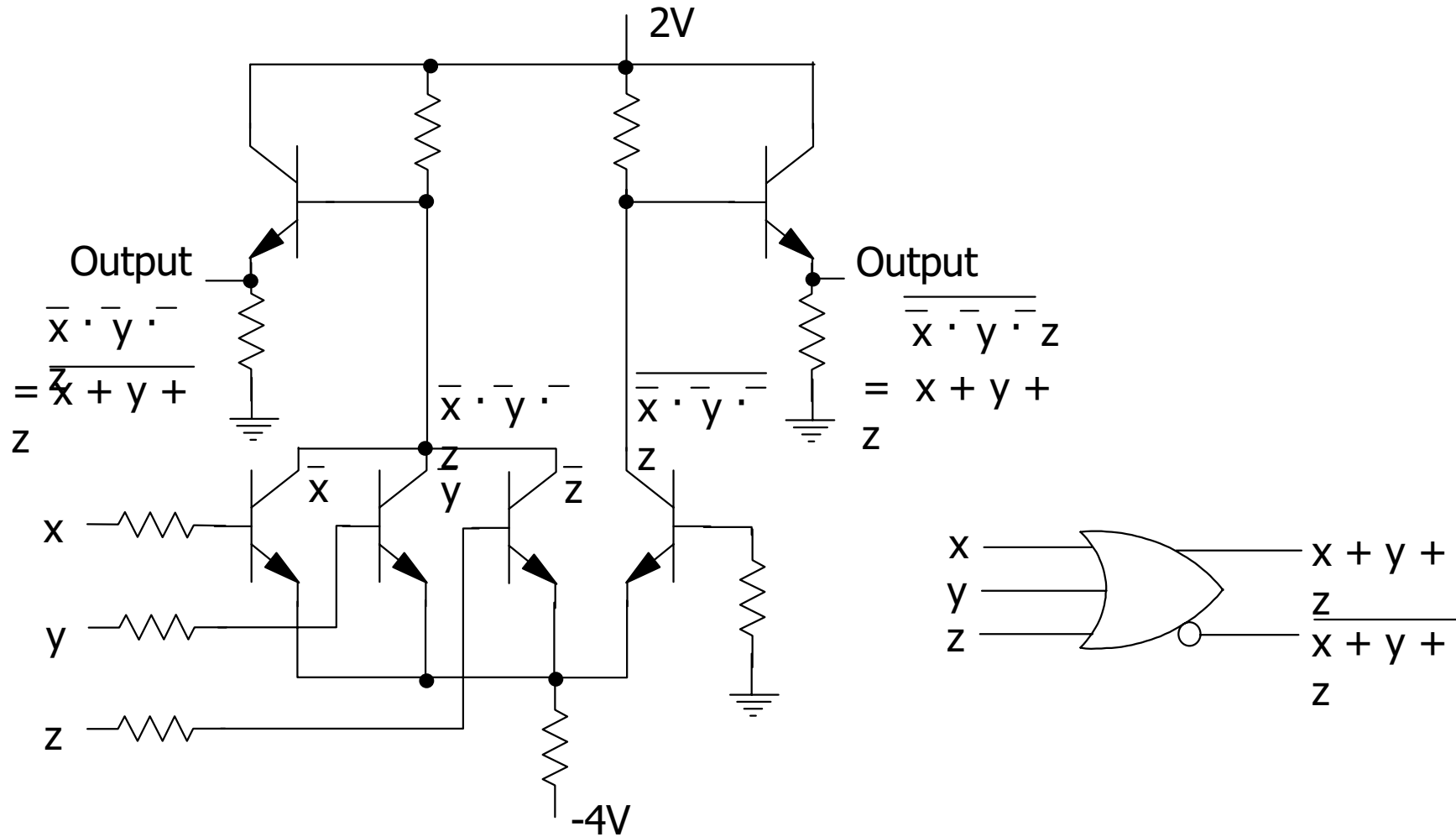

# Logic Operation of ECL gates

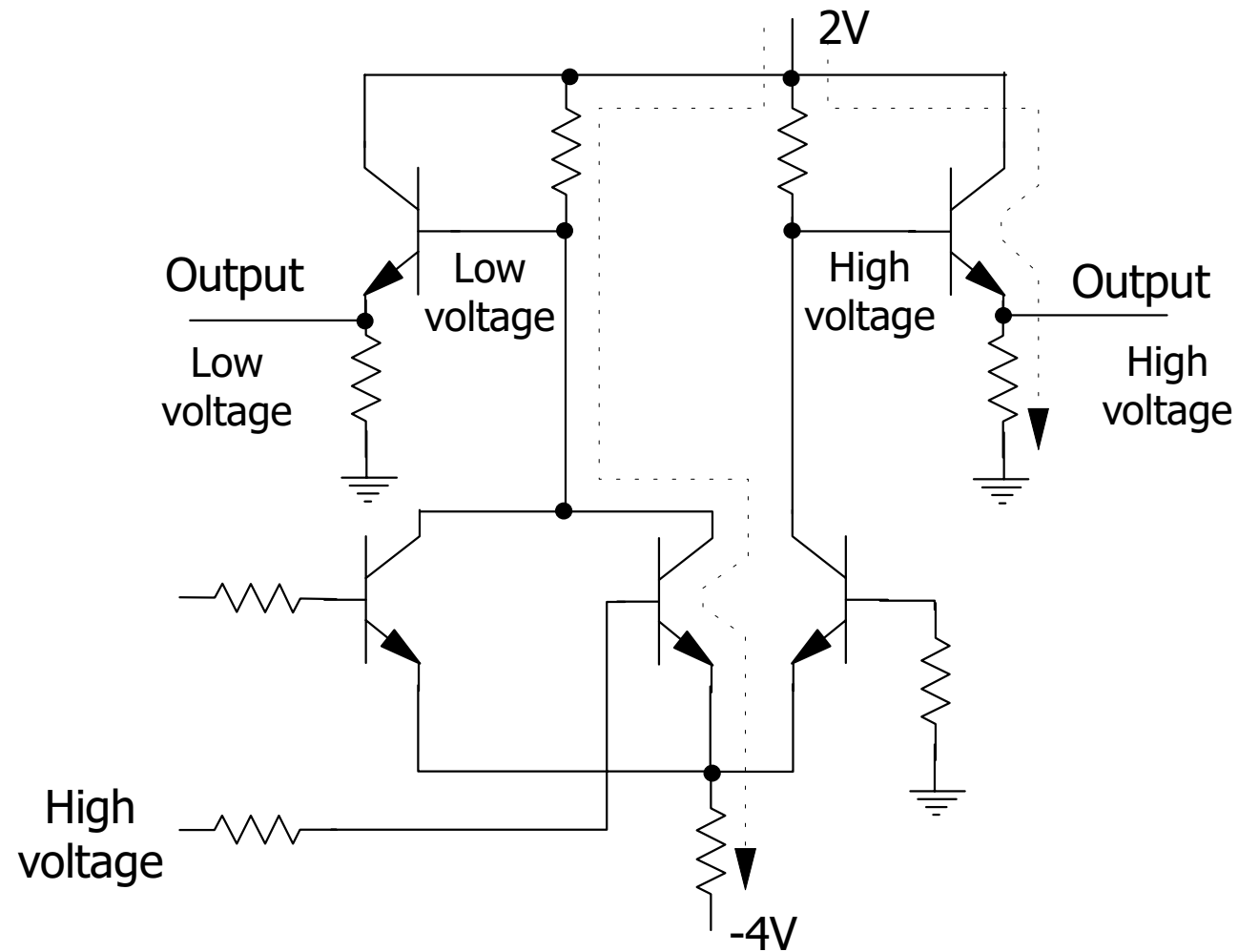



# Logic Operation of ECL gates

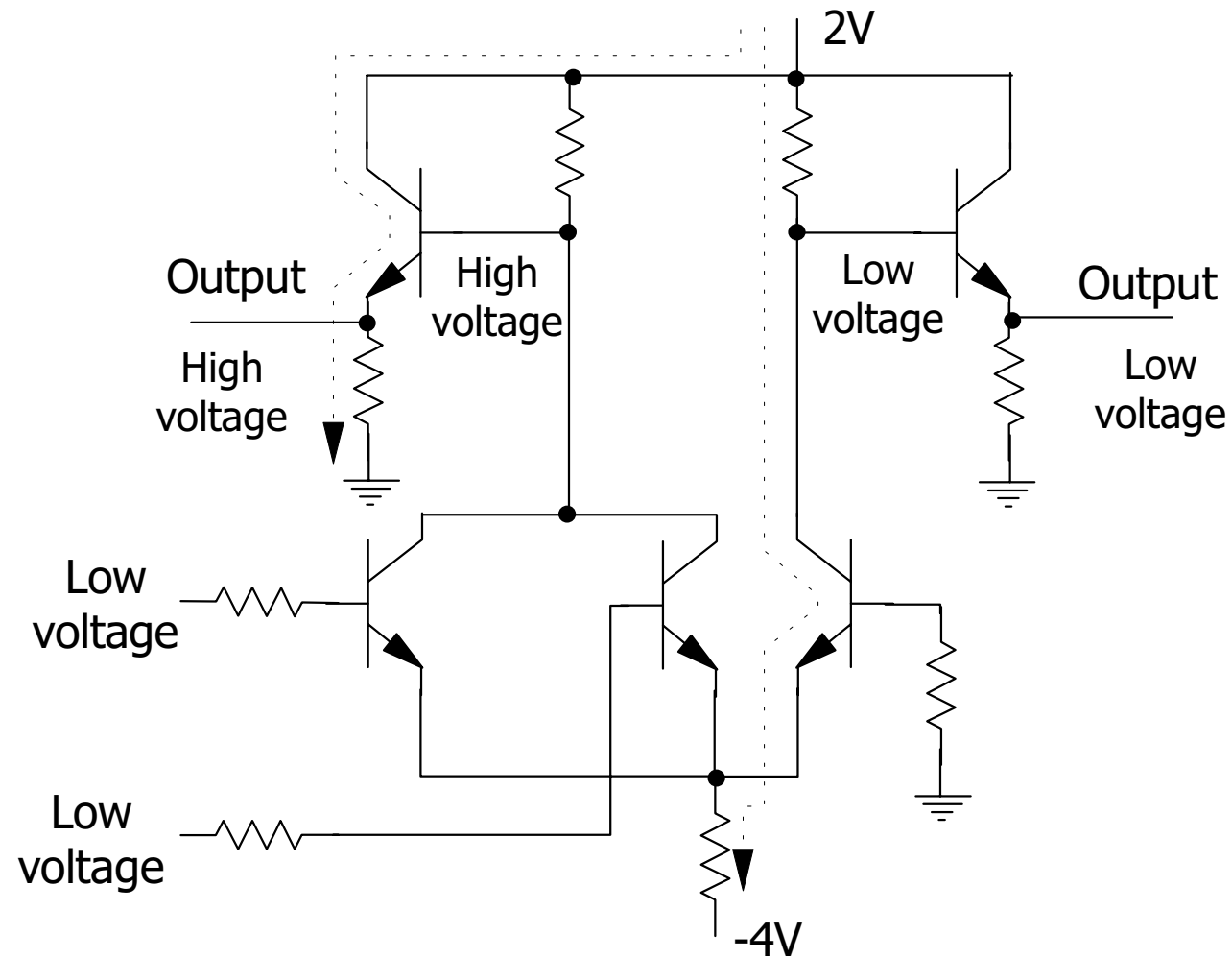

# Wired-OR of ECL Gates

---

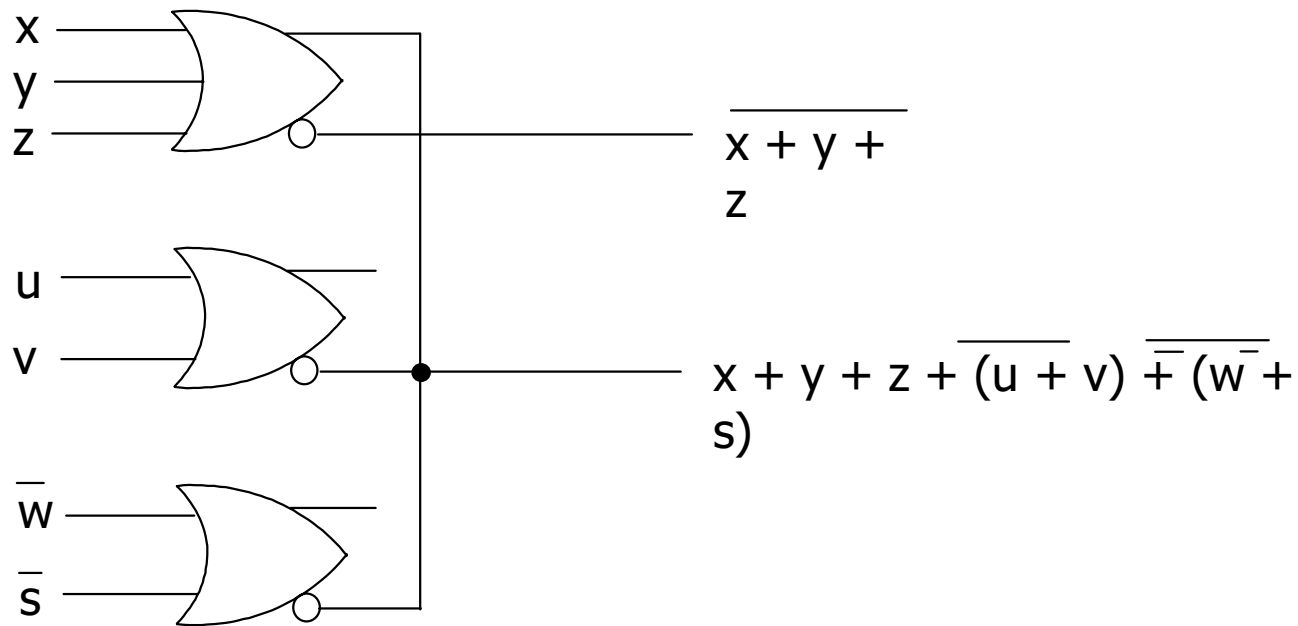

# Multiple-Output ECL gates

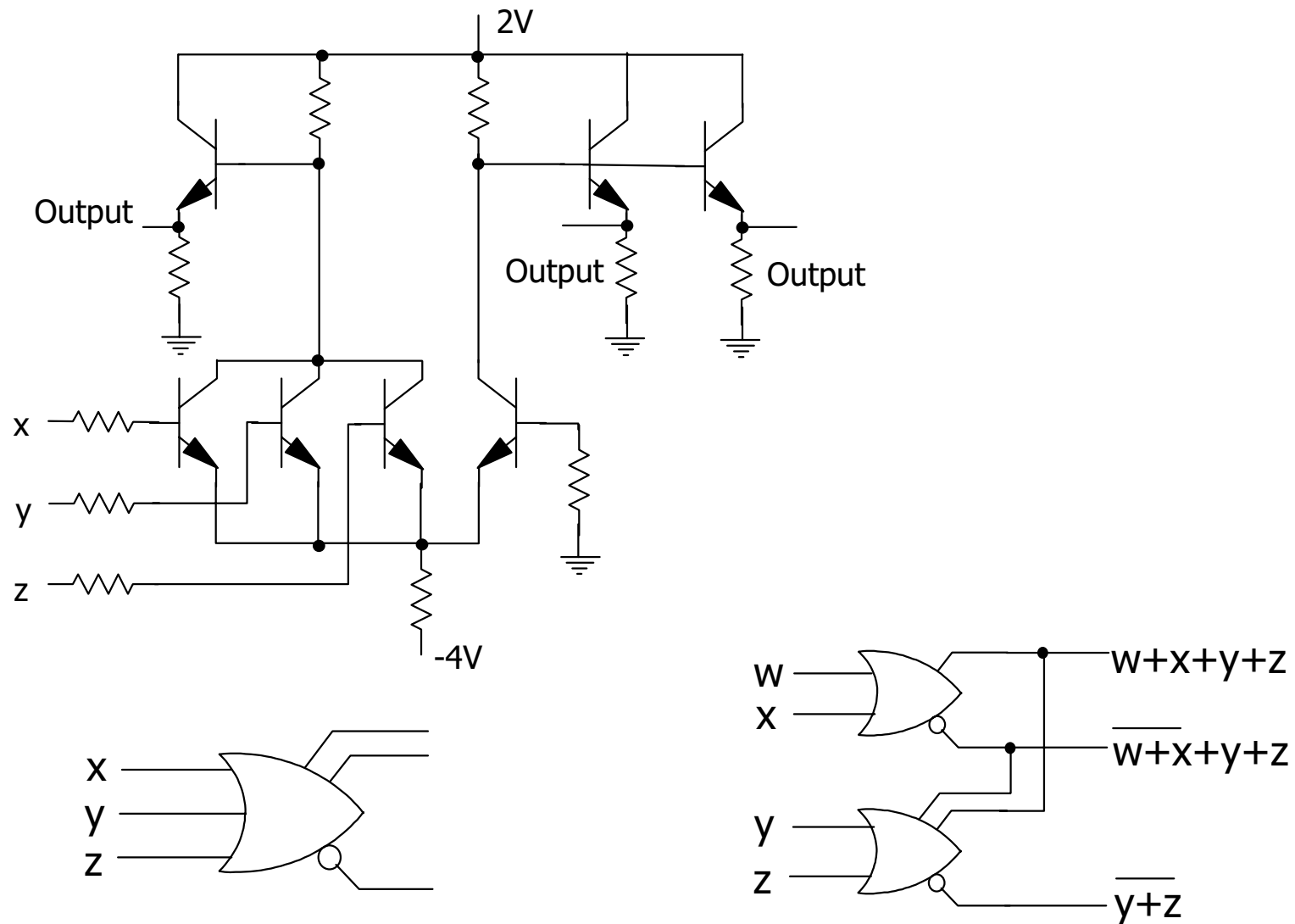

# Examples

